

Electronic Heat and Cooling Meter

zelsius®



with 2" Coaxial-Measuring Capsule

Table of contents

1	Introduction	4
2	Operation with the Button	5
2.1	Level Display	5
2.2	Important Special Symbols	5
2.3	Types of Operation.....	6
2.3.1	Short keystroke (S).....	6
2.3.2	Long keystroke (L).....	6
2.3.3	Holding the button (H).....	7
2.3.4	Submenus	7
2.4	Numerical entry with the button	8
3	Automatic Displays	9
3.1	Flow rate indicator	9
4	Display Menus	10
4.1	Main display: Heat/Cooling Energy	10
4.2	Volume	10
4.3	Segment test	10
4.4	Supply temperature	11
4.5	Return temperature	11
4.6	Temperature difference.....	11
4.7	Flow rate.....	12
4.8	Actual power	12
4.9	Heat / cooling energy on S.R.D.	13
4.10	Date of S.R.D.	13
4.11	Consumption previous year (Heat/Cooling Energy)	14
4.12	Monthly consumption	14
4.13	Monthly statistic (Heat/Cooling Energy).....	15
4.14	Device number	16
4.15	Customer number	16
5	Service menus	17
5.1	Sensors and installation location	17
5.2	Type number	17
5.3	End of calibration validity	17
5.4	Date and time.....	17
5.5	Software version	18

6	Status Messages & Errors	19
6.1	Status messages.....	19
6.2	Error displays	20
7	Technical Data	21
7.1	Data sheet.....	21
7.2	Optical interface	22
7.3	M-bus (optional)	22
7.4	Remote readout output (optional)	22

1 Introduction

Thank you for having purchased **zelsius®** one of the most modern heat meters available on the market today.

A lot of helpful functions and menus will assist you in getting better acquainted with your use of energy and your pattern of consumption.

Because zelsius® allows you the possibility of controlling your own pattern of consumption, you will, in time, be able to save costs.

The following operating instructions will explain to you how to use these possibilities. A number of statistic functions will assist you in doing so. The expressive symbols in the display assist in making this easier. A user-friendly interface and menu navigation make working with zelsius® a pleasure.

A few functions, such as the indication of errors dependent on the system, are displayed automatically. These indications do not disappear until the error has been corrected.

Not all of the special symbols represented on the right will be used by your measuring device. Details can be found in the corresponding chapters resp. in the short operating instructions enclosed with the device.

A single colored button is used to call up the individual displays.

Should you have any questions please call or contact us at info@zenner.de

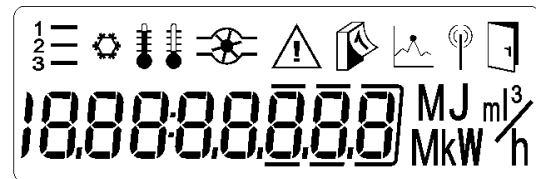

LC-Display with special symbols

2 Operation with the Button

2.1 Level Display

When working with comprehensive menu structures, extending over several levels, it is important to know in which level of the display matrix one is located. All successively displayed menu items are referred to here as *levels*.

Each menu item in a level can be addressed successively using the button. All displays belonging to one level have the same index. This is made easier by the display of a positioning indicator located in the upper left-hand corner of the display. It indicates the index of the level in the following manner „1—“, „2—“, and „3—“.

(Further details on this can be found in the display overview on Page 23.)

2.2 Important Special Symbols

zelsius® has a number of special symbols which, in addition to the positioning indicator, make it easier to assign them to the functions being displayed.

For example, a calendar sheet appears with a consumption value to indicate the „meter reading on the S.R.D.“. The other symbols are just as easy to interpret.

Menus with a door symbol, have sub-menus, i.e. further displays are hidden behind these menus (for example, monthly values etc.) or these values may be changed using the Editor (for example: the bus addresses). The functionality of the Editor is described separately (should your device have such an Editor). The Editor can be identified by a blinking digit.

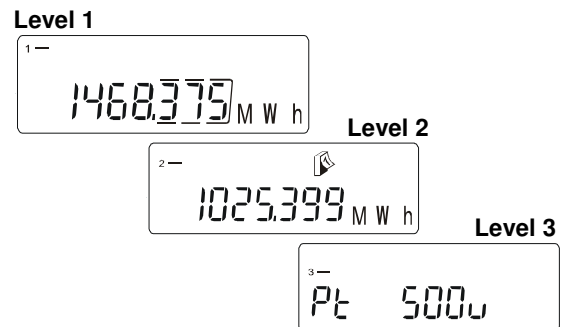

Flow rate indicator



Symbols for supply/return temperature



S.R.D., memory value



Symbol for cooling meter



Submenu



Threshold value, statistic



Warning notice



Interface operation

2.3 Types of Operation

The button recognizes three different types of operation in it's standard mode.

- Short keystroke (S)
- Long keystroke for approx. 2 seconds (L)
- Holding the button for at least 5 seconds (H)

2.3.1 Short keystroke (S)

Pressing the button briefly causes the display to switch line-by-line from top to bottom. The order is defined by the menu structure. When the last menu item has been reached, you can return to the first item again by pressing the button (loop). Using the positioning indicator (upper left-hand corner), you can see which level you are located in. If the button is not used over a longer period of time then the menu automatically switches back to level 1, menu item 1 in the main menu.

2.3.2 Long keystroke (L)

To reach a submenu from a menu item, the button must be pressed for approx. 2 seconds. The door symbol in the upper right-hand corner of the display will then disappear briefly and reappear. You may then release the button and the menu switches to the submenu. (For details see the chapter „Submenus“)

Note: 

When using the long keystroke (L), the display is not actualized, until the door symbol has appeared and you have released the button.



Switch to the next menu item

Short (S)



Jump to a submenu

Long (L)



Go to next level or return to the access menu

Hold (H)

Representation of the types of operation for the button in standard mode

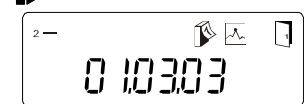
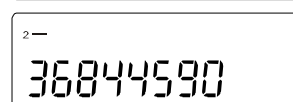
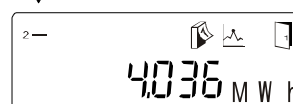

Switch to a submenu using the „Long keystroke“ (L)

2.3.3 Holding the button (H)

Normally, holding the button for more than 5 seconds switches the display to the next level, regardless of which line you are located in within the level. The display is automatically updated after this switch and you can then release the button. If you are located in the last level then holding the button brings you back to level 1.

Almost all menu items, regardless of which level, have an automatic reset to menu item 1 in level 1 after a so-called reset time of approx. 2 minutes.

A few functions may have a longer reset time. This is however indicated separately in the description of the function.

The symbol used in the overview for the „Hold“-function is the letter „H“ within an arrow symbol and two additional bars.

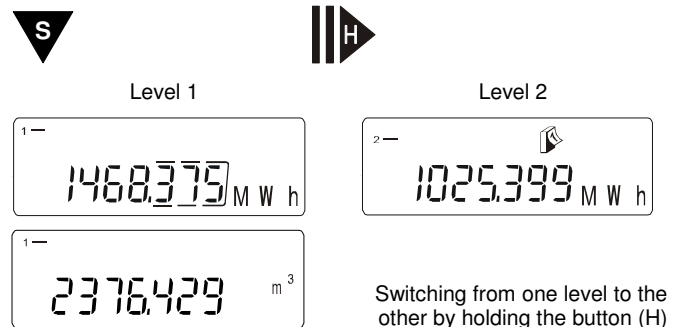

2.3.4 Submenus

Menus with a door symbol have submenus, i.e. further displays which are hidden behind these menus, for example: monthly values. Submenus are comparable with the opening of further, till now, hidden levels (see also *Display Overview page 23*).

The switch to a submenu takes place using the long keystroke (L) and differs at this point from a simple change in level.

The return from submenus is triggered over the hold-function (H) described above.

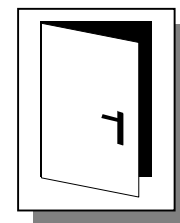

2.4 Numerical entry with the button

The Editor, which can be used to change numerical values such as time etc., can be used at several points within the menu structure and is therefore universal.

The Editor can only be reached over items in the menu which display the door symbol and have no submenu, but rather an editable value.

The display indicates that it is in Editor-mode by blinking with the first digit, similar to the way a digital watch blinks when the time is being set. By holding the button (H), you can leave the Editor directly at your current position, whereby the values changed up to this point are taken over. Should you be in the Editor-mode by mistake and have accidentally changed one of the values, you can restore the old value by not using the button (**escape function**) for a period of approx. 30 sec. The meter then switches automatically out of Editor-mode. The meter accepts the set value by holding the button (H), as well as by switching past the eighth position in the display.

You can change only the digit currently blinking by repeatedly pressing the button (short keystroke). The long keystroke is used (L) to jump to the next digit or to a certain point in the display. When you have reached the desired position you can increase the digit from "0" to "9" by repeatedly pressing the button.



Short

Switch to next digit



Long

Switch to next position



Hold

Take over value

Button assignment in the Editor

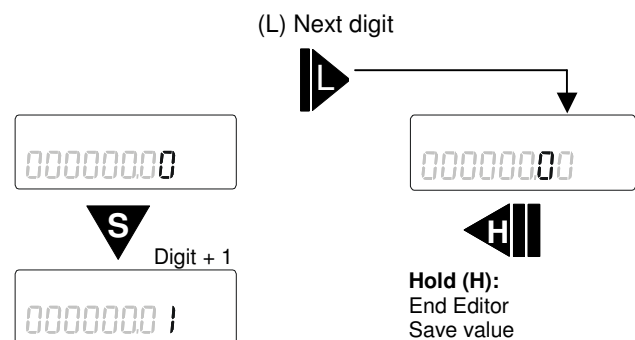

3 Automatic Displays

3.1 Flow rate indicator

As soon as the heat meter's volume transmitter is running and the flow is registered, the symbol to the right appears (only) in the main display. If the system is not running, i.e. there is no flow and no energy is measured, then the symbol turns itself off. However, this symbol gives no indication about a possible false installation regarding the flow direction (negative count).

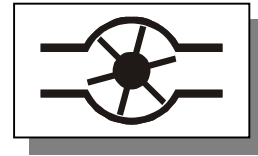

Note:  All the menus and functions represented here are examples and therefore can differ somewhat from those of your device. This is especially true for the number, sequence and configuration of the available levels.

4 Display Menus

4.1 Main display: Heat/Cooling Energy

The meter's main display shows the actual heat consumption, which is used for billing. It is displayed in MWh or kWh with individual decimal places, which are further distinguished by a frame. The display of the current consumption is also the display to which the meter automatically switches back to after a certain period of time.

To differ between heating and cooling energy, a cooling symbol appears on the display of cooling or combined heat/cooling meters.

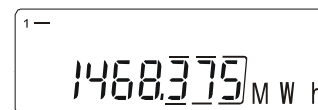

Heat energy

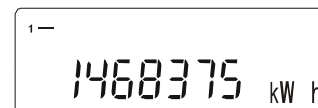

Alternative display in kWh

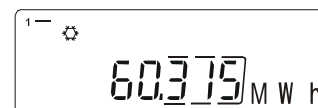

Cooling energy

4.2 Volume

This value represents the entire water volume which has flowed through the meter since its installation and is used for the energy calculation. It is however of little significance, except for determining the flow rate over a relatively short period of time.

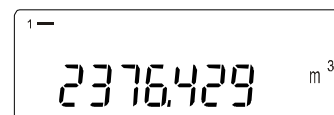

4.3 Segment test

To check a malfunction or the constant flashing of individual segments on the LCD, all segments are switched on and off cyclically. Thus, the error-free operation of the LCD can be tested. This helps to eliminate readout errors due to faulty segments.

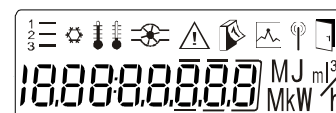

4.4 Supply temperature

The heating system's supply temperature or the higher temperature which is used to calculate the temperature difference, is displayed with a resolution of maximum one hundredth degree Celsius (0,01 °C).

The corresponding symbol, a thermometer displaying a high temperature, is switched on.

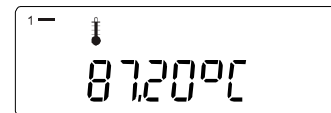
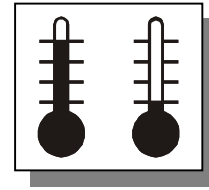

4.5 Return temperature

For completion, the return temperature, i.e. the lower temperature, including the corresponding symbol is displayed.

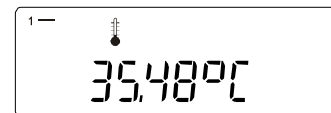

4.6 Temperature difference

The temperature difference is decisive for the energy calculation. The absolute values of the supply and return temperatures play a less important role. These can be used only for potential comparisons with insert thermometers and the like, during the initial operation of the system or during system checks.

The temperature difference is symbolized by the display of both the thermometers in the upper left-hand corner of the LCD.

The display resolution averages, as was the case with the previous displays, one hundredth degree Celsius.

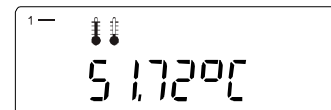

4.7 Flow rate

The display of the current flow rate, i.e. the volume, which flows through the meter per displayed unit, is often used during the initial operation as a quick way of checking the heat meter's operation and for eventual system adjustments, thus the fallback delay is also set here to approx. 5 minutes.

However, with a simple keystroke this is lifted and you switch to the next menu item.

For reasons of energy conservation, the flow rate is not actually calculated until the moment that the flow rate menu is displayed.

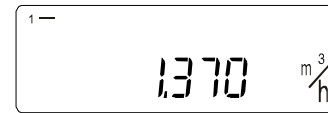

The calculation of the flow rate, made as a first approximation, may still be flawed. However, this is of little importance, due to the high resolution volumetric measuring device. The calculation is definitely adequate enough for adjusting the system.

4.8 Actual power

The actual power is derived resp. calculated directly from the flow rate. All comments pertaining to the accuracy of the flow rate display are here also valid.

The unit is displayed, like the main energy display, in MW resp. KW. Only the total accumulated power is displayed regardless whether it concerns the cooling or the heating power of the system.

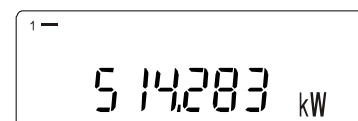

4.9 Heat / cooling energy on S.R.D.

On the special reading date (S.R.D.), the main display's meter reading, i.e. the energy accumulated to date, is taken over by the memory and replaces the old reading saved therein. This data is always saved during the transition to the SRD at 12.00 pm. For example, on the SRD „01.01.“, the reading is saved at night during the transition from the 31.12. to the 01.01.. The meter reading and S.R.D. date share the same symbol (daily calendar).

At cooling meters this display appears with a additional cooling symbol. At combined heating/cooling meters, both displays appear based on a common special reading date.

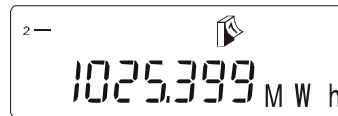
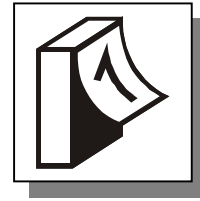

Heat energy on S.R.D.

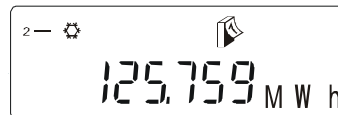

Cooling energy on S.R.D.

4.10 Date of S.R.D.

The special reading date (S.R.D.) is an annual event, at which the meter files the currently displayed meter reading in it's memory and then after a year, at the same date, overwrites this reading with a new one. It is usually used to provide all meters from one billing unit with the same readout period, regardless of when the meter is actually read. In the present case, this would be exactly one year. The date of the S.R.D. is displayed together with the calendar symbol in the following manner „dd.mm“.



The S.R.D. date is set ex works to a generally common billing date and can only be changed by service personnel with the appropriate software.

4.11 Consumption previous year (Heat/Cooling Energy)

The total consumption for the previous billing period (previous year) is also directly connected with the „Energy on the S.R.D.“, i.e. the difference of the last two S.R.D.s. The last annual consumption based on the S.R.D. is always represented here. If this is set, as is customary, to the 1st of January („01.01.“), then the complete consumption for the previous year can actually be read here. The consumption for the previous year can be identified by the combined symbol, flow rate indicator and calendar sheet. At cooling meters the cooling symbol is displayed third. It is very important to pay attention to the difference between the displays of the meter reading, i.e. the “Energy on the S.R.D.” or storage of an instantaneous value and the function “**Consumption** previous year” described here, a consumption value based on the period of a year!

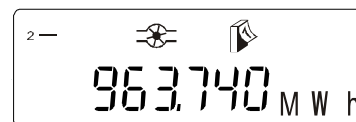
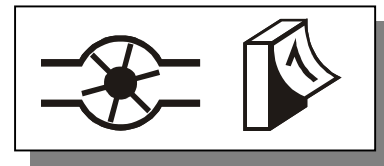

Consumption previous year
Heat energy

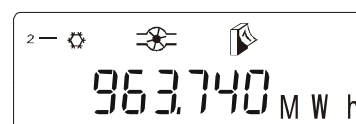

Consumption previous year
Cooling energy

4.12 Monthly consumption

In this menu item, the energy (heat or cooling energy) consumed to date for the current month is displayed along the lines of the consumption of the previous year. This is symbolized by a calendar sheet plus a statistic symbol, because the complete monthly statistic, over a period of at least 18 months, is hidden behind this consumption value in a submenu and can be displayed. These hidden submenus can be identified by the door symbol which appears in the upper right-hand corner of the LCD.

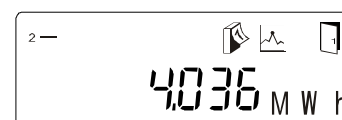
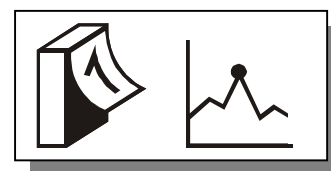

Monthly consumption
Heat energy

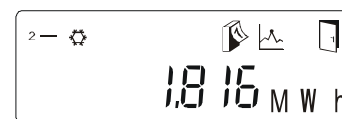

Monthly consumption
Cooling energy

The listings of still older monthly consumptions is described in the following.

4.13 Monthly statistic (Heat/Cooling Energy)

Each completed monthly consumption is saved by the meter in its statistic register. The number of values is dependent on its current setting and memory size. At least 18 monthly values are guaranteed. The date you are interested in is displayed first and from here, you can switch to the corresponding meter reading. You can reach the statistic register from the current monthly consumption (heat or cooling energy) by using the long key-stroke (L). During the switch to the submenu, the date of the first of the current month displayed.

(Example: „d 01.02.03“)

Behind this, you can find the monthly value (heat or cooling energy), which was present at the transition to this date at 12.00 pm and can be reached by using the long keystroke (L). With the short keystroke (S) you can return to the date display.

Now, you can move to other months of interest and the monthly values behind these by scrolling with the short keystroke (S).

Date	Meter reading
01.06.2003	3,450 MWh
01.05.2003	3,200 MWh
01.04.2003	2,768 MWh
01.02.2003	1,403 MWh
•	•
•	•
•	•
01.05.2002	0,55 MWh

Example: Table with an overview of a monthly statistic

The same monthly statistic as with heat meters exists with cooling meters with a additional cooling symbol on the display. At combined heat / cooling meters, two separated statistics can be displayed appearing after the respective current monthly consumption (heat or cooling energy).

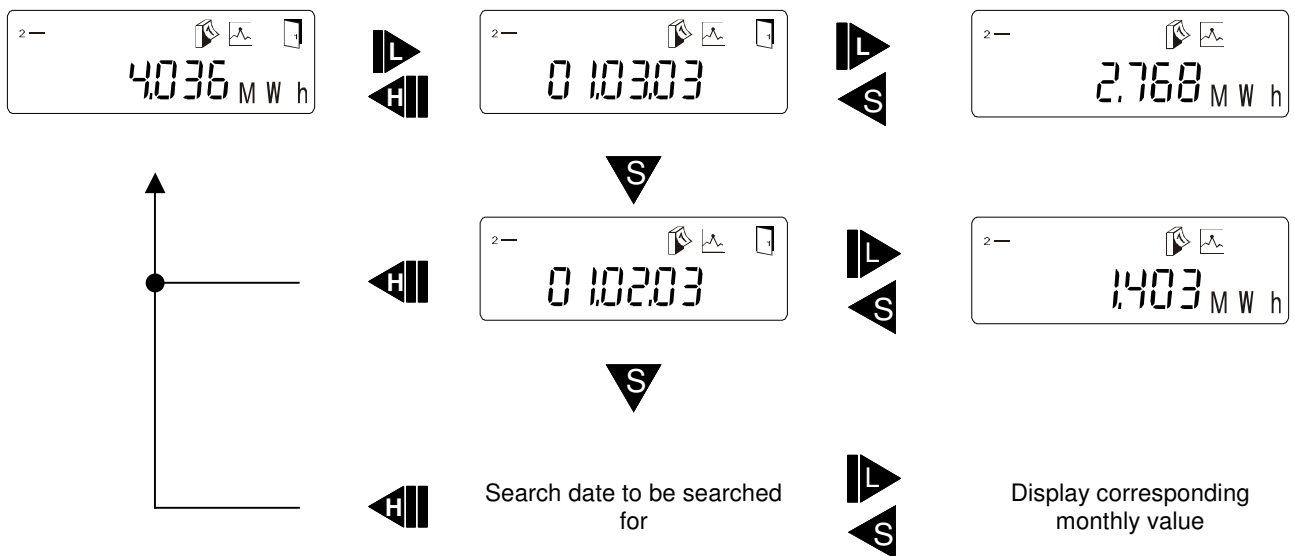

4.14 Device number

The device number is the number defined during the production of the meter and is used for the unequivocal identification of the meter. The device number is also located on the meter itself, usually on the front with a bar-code inscription.

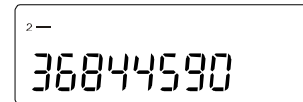

4.15 Customer number

If required, client-specific numbers can be programmed. This can be done during the production phase or subsequently by the customer or other authorized persons. The number of digits is limited to the 8-digit display preceded by a „1“.

The customer number is a special function and not available in all meters.

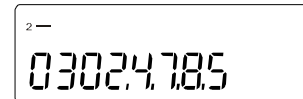

5 Service menus

5.1 Sensors and installation location

The type of temperature sensor being used, normally the „Pt-500“, as well as the installation location, return flow („r“) or supply flow („r“), required for a correct heat measurement are displayed here and can be checked by the service personnel.

A meter which is designed for return flow (normal case) should never be used in the supply flow!

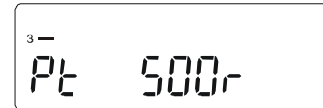

5.2 Type number

The type number contains encoding for the equipment resp. the meter's software settings (item number). This can become necessary in the uncommon case of queries from the customer service center at the factory.

(Only for authorized personnel)

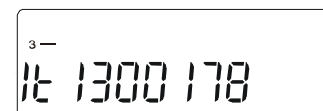

5.3 End of calibration validity

If the meter is calibrated and the calibration is successfully completed then the date valid for the end of the calibration validity is filed here. This period is currently set to 5 years and ends at the end of the displayed calendar year. At the same time, a software lock is internally activated which allows no access to the parameters set during the calibration.

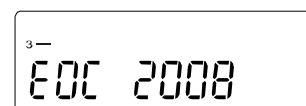

5.4 Date and time

An automatic shift from summer to winter time is not available. If a door symbol appears, then the time can possibly be changed resp. corrected using the Editor.

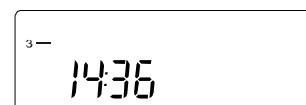
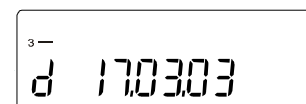

5.5 Software version

The software version is identified by an „S“ in brackets, followed by the version number. It is used for the identification of the current software status, which in turn gives information about the availability of certain functions. This is only important for trained service personnel.



6 Status Messages & Errors



6.1 Status messages

Status messages display the working condition of the meter for the consumer in an easily comprehensible manner. Some working conditions are displayed with the help of symbols (see the table below). Others, are in turn represented by a warning triangle, in order to not overload the display with a multitude of symbols. The corresponding errors or defects are listed separately on page 20 in the chapter „Error Displays“.



Note : 

The status messages in the table below appear only in the main display (Energy)!

In all cases, in which the warning triangle represents a status message, you should first check whether the problem is permanent or occurs only temporarily.

A few errors can be conditional upon the system and do not necessarily mean that the meter is defect.

Please check such conditions ahead of time by switching to the error display (as a rule level 3, display „Err_xxxx“) and analyzing the problem using the tabular values on Page 20 (Chapter „Error Displays“).

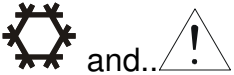
Symbol	Status	Display	Event / Reaction
	Flow existent		
	Indicator for a change in the operational state, for example an error.	Always on.	Meter has identified a certain state. Details can be found in the menu „Error display“.
	Data transfer on the interface.	Only when data is being transferred.	
	Emergency operation!	Always on.	Energy is still being displayed and calculated correctly. All other displays are blocked and the button also no longer reacts. Replace device!

6.2 Error displays

When the meter identifies indications for certain changes in the working condition of the meter, such as calibration expiration or states indicating an internal problem, it displays these with an error message in the following manner „Err_ XXXX“. The following table gives information about further details.

If a major defect exists, then this is displayed **directly instead of the main display**.

All states with the status value ≥ 8000 belong to the group of major, non-reparable errors.

In all other cases, when the warning triangle appears in the main display, the value and with it the corresponding error, can be determined subsequently in the menu item Error Display. The recommended reactions can also be found in the table below.

If the error can be corrected, then the status messages disappear. Error values which cannot be directly found in the table consist of the sum of several different errors.

For example: (Error 1005 = Error 1000 + Error 5, but: Error 8004 = write-error on Flash)



Error values less than 8000 can be read over the interface. Up from error number 8000, the interface can only be used for setting parameters and no longer for readouts on location.

Error	Device state	Recommended reaction	Display location
1	Hardware defect	Replace device.	Error display
2	Interruption supply flow sensor		
3	Interruption return flow sensor		
4	Hardware defect		
5	Short circuit supply flow sensor		
6	Short circuit return flow sensor		
100	Device in emergency operation		
200	Manipulation operation	Clarify unauthorized access.	Error display
1000	Battery-life exceeded	Replace device (recalibration).	
2000	Calibration period expired		
4000	Not yet documented		
8000	Access Controller to EEPROM not possible	Replace device (hardware defect).	Main display, Device not functioning!
8001	Header- Checksum in EEPROM defective	Major error. Cannot be corrected on location. New parameters from the factory or test center are required.	
8002	Backup-Checksum in EEPROM defective		
8003	Static- Checksum in EEPROM defective		
8004	Write error on Flash memory		
8005	EEPROM write-/read error		

Example : Error 1005 means, that the battery-life has been exceeded and a short circuit in the supply flow sensor was identified.

7 Technical Data

7.1 Data sheet

Type		zelsius® heat meter (cooling meter)		
Temperature range HC	°C	1 ... 130 (5 ... 30)		
Temperature difference range	Kelvin	3 ... 100		
Type of temperature sensor		Pt 500		
Temperature range sensors	°C	0 ... 130 (Silicon)		
Dimensions sensors		Ø 5,0 mm Length cable 1,5 m (5 m max.)		
Nominal flow	Qp m³/h	0,6	1,5	2,5
Connection width	DN mm	15	15	20
Highest flow rate	Qs m³/h	1,2	3,0	5,0
Transitional flow rate Qt (Cl.A)	l/h	60	150	250
Minimum flow Qmin (Cl.A)	l/h	24	60	100
Nominal pressure PN	bar	16		
Media temperature VMU	Tmax °C	10 ... 90 (5 ... 90)		
Typ. starting flow rate (horizontal)	ca. l/h	4		
Measurement dynamics horizontal / vertical		1:100 / 1:50	1:100	1:100
Display area LC-Display		8 digits, 3 after decimal point		
Battery	V	Li 3,0		
Battery-life	years	≥ 6		
Protection class		IP 54		
Ambient temperature	°C	0 ... 55		
Weight measuring capsule	g	ca. 680		
Connection thread capsule		G 2 B		

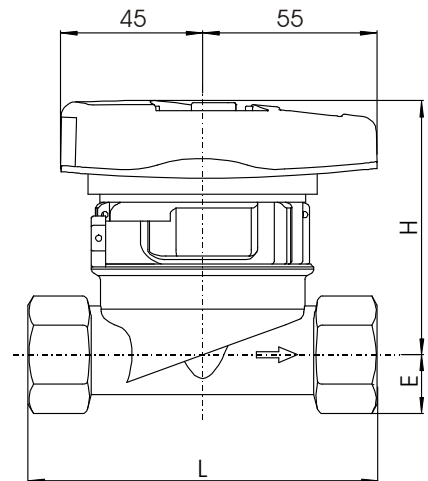

Dimensions			
Height	H	mm	80
	E _{max}	mm	18,5
Width heat computer		mm	72
Length heat computer		mm	100
Installation length EAS body	L	mm	110

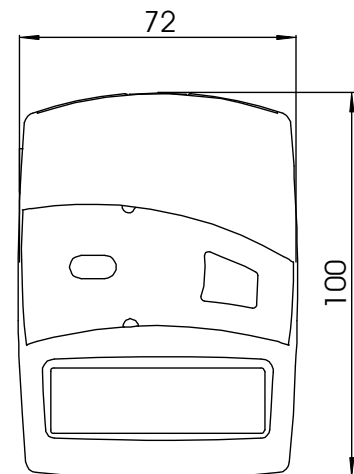

Single pipe connection (EAS)

Article	Installation length	Connection
EAS	110	1/2" IG
		1/2" AG 15 mm solder
		3/4" IG
		3/4" AG 18 mm solder ¹⁾
	130	22 mm solder
	1" AG	

The EAS in the installation kit is delivered with a temporary cover, incl. a sealing kit.
1) optional with temperature sensor input

7.2 Optical interface

In all cases where a quick and secure readout resp. parameterization is required, the optical interface available in every meter can be used. The interface's baud rate is, for the most part, equivalent to the ZVEI-standard. It is firmly set to 2400 baud.

7.3 M-bus (optional)

The M-Bus interface offers a further possibility for a remote data readout. The interface conforms with the standard according to EN 1434.

The maximum data transfer rate is higher than that of the optical interface and is equivalent to 9600 baud.

The interface is not retrofittable, but rather optional, i.e. it must be ordered with the meter. The 2-core cable for the connection to the M-Bus network is firmly attached. The sequence of the connection of the cores is arbitrary and interchangeable.

Further information about M-Bus-networks can be found in our brochure „Data Transfer Systems“.

7.4 Remote readout output (optional)

A version with a remote readout output can be selected instead of the M-Bus. It is unfortunately not possible to have both at once. Only a firmly attached cable is included in delivery. You must do the external circuitry yourself. (See drawing on the right).

Data remote readout output	
Load	max. 30VDC / 20 mA
Switching output 1,2	Open Drain, n-canal FET
Cable	D= 4 mm, 2 wires
Cable length	1,10 m (standard)

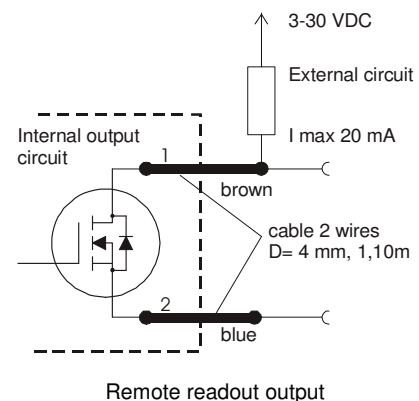

The outputs emit a pulse with an output frequency of 1 Hz and a pulse with factor of approx. 1:1.

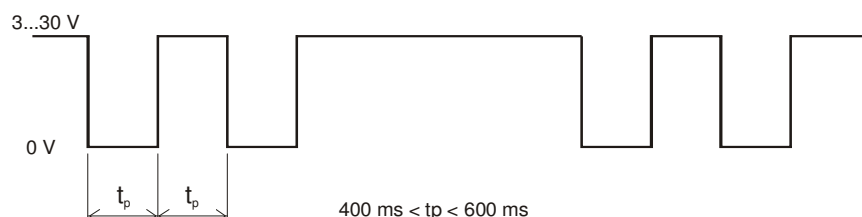

Product Description Heat Meter

Electronic Heat and Cooling Meter zelsius®

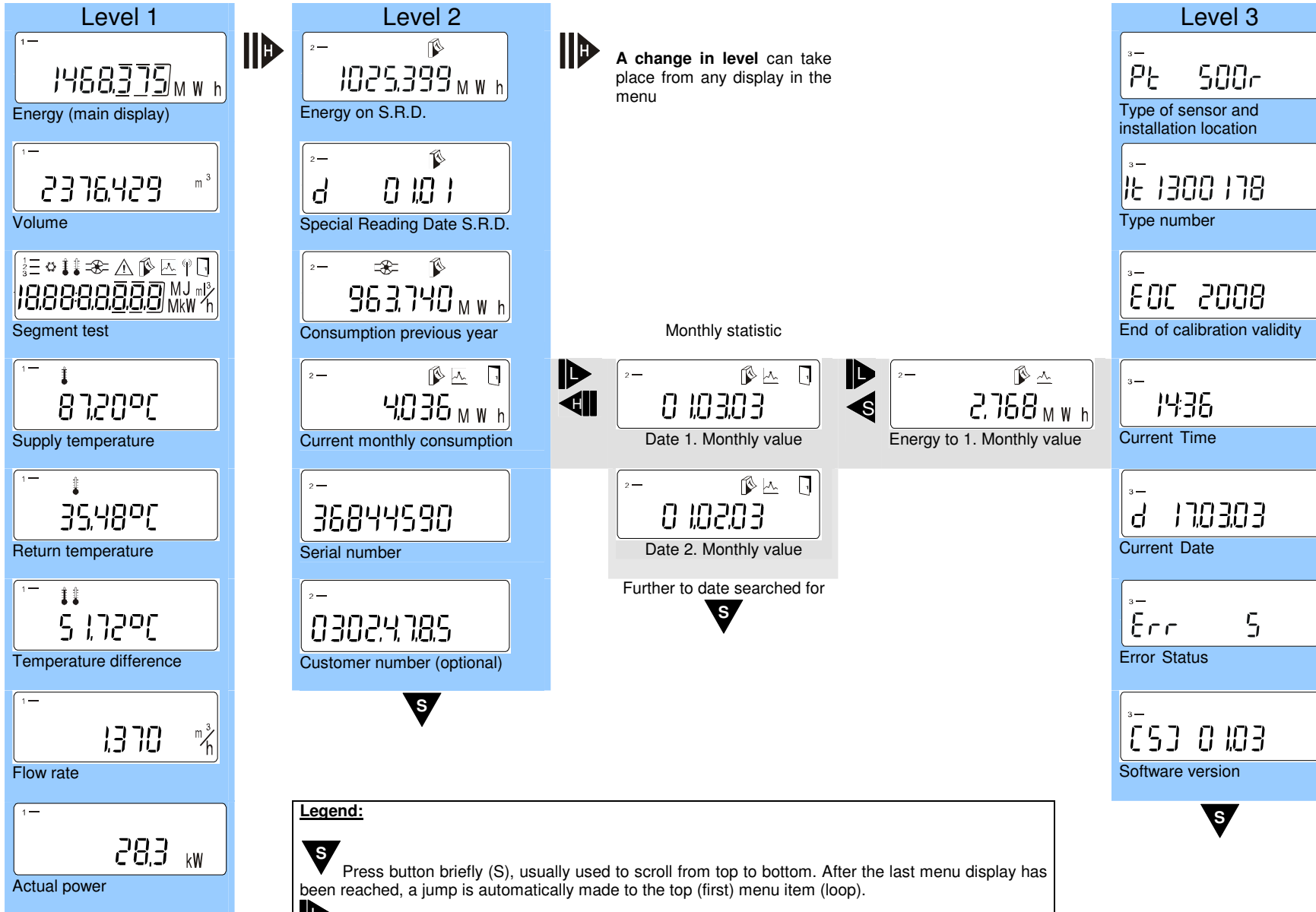

ZENNER®

... because every drop of water counts.



A change in level can take place from any display in the menu

Legend:

-  Press button briefly (S), usually used to scroll from top to bottom. After the last menu display has been reached, a jump is automatically made to the top (first) menu item (loop).
-  Press button for approx. 2 sec.(L), wait until the door symbol (upper right in the display) appears and then release the button. Then the menu is updated resp. a jump is made to the submenu
-  Hold button (H) until the level is changed or a return from the submenus occurs.

Product Description Combined Heat / Cooling Meter

Electronic Heat and Cooling Meter zelsius®

Level 1

1- 1468.375 M W h
Heat energy (main display)

1- 60.375 M W h
Cooling energy

1- 2376.429 m³
Volume

1- 188888888 MJ m³ / h
Segment test

1- 87.20°C
Supply temperature

1- 35.48°C
Return temperature

1- 5.172°C
Temperature difference

1- 1.370 m³ / h
Flow rate

1- 28.3 kW
Actual power



Level 2

2- 1025.399 M W h
Heat energy on S.R.D.

2- 1025.399 M W h
Cooling energy on S.R.D.

2- d 0.101
Special Reading Date S.R.D.

2- 4.036 M W h
Current monthly consumption heat energy

2- 1.816 M W h
Current monthly consumption cooling energy

2- 36844590
Serial number

2- 03024.785
Customer number (optional)



A change of level can take place from any display in the menu

Monthly statistic



2- 0.10303
Date 1. Monthly value heat energy



2- 2.768 M W h
1. Monthly value heat energy



Date 1. Monthly value heat energy

2- 0.10203
Date 2. Monthly value heat energy

Date 2. Monthly value heat energy



Further to date searched for



2- 0.10303
Date 1. Monthly value cooling energy



2- 2.160 M W h
1. Monthly value cooling energy



Date 1. Monthly value cooling energy

2- 0.10203
Date 2. Monthly value cooling energy

Date 2. Monthly value cooling energy



Further to date searched for

Legend



Press button briefly (S), usually used to scroll from top to bottom. After the last menu display has been reached, a jump is automatically made to the top (first) menu item (loop).



Press button for approx. 2 sec.(L), wait until the door symbol (upper right in the display) appears and then release the button. Then the menu is updated resp. a jump is made to the submenu



Hold button (H) until the level is changed or a return from the submenus occurs.

Level 3

3- Pt 500r
Type of sensor and installation location

3- It 1300178
Type number

3- EOC 2008
End of calibration validity

3- 1436
Current time

3- d 17.03.03
Current date

3- Err 5
Error status

3- [53] 0.103
Software version

Index Technical Terms

Technical Data

Dimensions	21
Data sheet	21
Interfaces	22
M-bus (opt.)	22
Remote readout output (opt.) .	22

Display Menus

Date	17
Date S.R.D.....	13
Flow rate	12
Calibration validity.....	17
Installation location sensors ...	17
End of calibration validity	17
Energy	10
Energy on S.R.D.....	13
Sensor type.....	17
Actual power	12
Monthly consumption.....	14
Customer number	16
Return temperature	11
Segment test	10
Device number	16
Software version	18
Status messages	19
S.R.D	13
Temperature difference	11
Temperature sensors	17
Type number	17
Time.....	17
Version.....	18
Volume	10
Consumption previous year	14
Supply temperature	11

Operation with Button

Types of Operation	6
Levels, level display.....	5
Holding the button (H)	7
Short keystroke (S).....	6
Long keystroke (L).....	6
Special symbols	5
Submenus	7

Automatic Displays

Durchflussindikator.....	8
--------------------------	---

Status Messages and Errors

Status messages.....	19
Error displays	20

Subject to technical change