

## s.142 bib-cock

3/8"-1" hot forged brass  
with 3/4" outlet and hose



### Features and Specifications:

- \* **Angle pattern** ball bib-cock with hose fitting,
- \* **Hot forged** sand blasted nickel plated brass body,
- \* Copper alloy brass according to **EN 12165** and **EN 12164** specification,
- \* **Pure PTFE** seats,
- \* Chrome plated brass ball for **longer life**,
- \* Adjustable packing gland stem design for **easy maintenance**,
- \* Enameled red **steel handle**,
- \* **UNI ISO 228** Male inlet thread,
- \* 3/4" threaded outlet complete **with hose**,
- \* 15 bar (Kg/cm<sup>2</sup>) non-shock cold working **pressure**,
- \* -15°C +150°C **temperature**.

The product described  
in this document meets  
the requirements of  
PED Directive 97/23  
and according to art.3  
par.3, it does not  
require CE marking.



**RUBINETTERIE UTENSILERIE BONOMI SRL**

VIA PADANA SUPERIORE, 27/29 - FRAZ. GILIVERGHE, 25080 MAZZANO (BS) - ITALY

Fax+39 030 2629498

Phone+39 030 212441

<http://www.rubvalves.com>

email: [sales.director@rubvalves.com](mailto:sales.director@rubvalves.com)

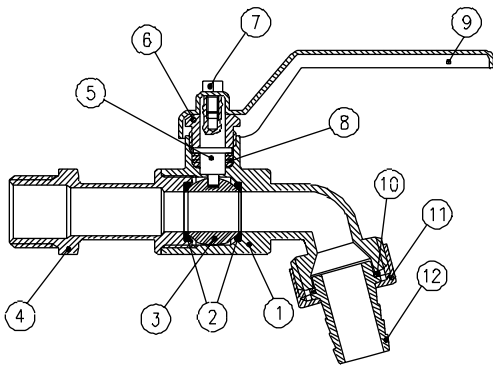

PART DESCRIPTION		Material	Q.ty
1	142 nickel plated body	CW617N	1
2	Seat	Ptfe	2
3	Chrome plated ball	CW614N	1
4	142 nickel plated end cap	CW617N	1
5	Nickel plated stem packing gland design	CW614N	1
6	Nickel plated packing gland nut	CW614N	1
7	Screw	Steel	1
8	Packing gland seal	Ptfe	1
9	Red handle	Steel	1
10	O-Ring	NBR	1
11	Nickel plated nut	CW617N	1
12	Nickel plated hose	OT63	1

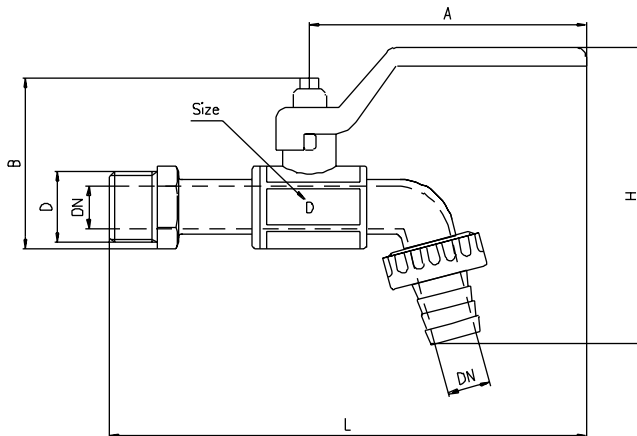

Codice	142CØP	142DØP	142EØP	142FØP
D (pollici)	3/8	1/2	3/4	1
DN(mm)	10	12	12	15
B (mm)	53	53	61	65
L (mm)	134	134	148	155
A (mm)	80	80	88	88
H (mm)	94	94	110	130

*Ask for additional information on the whole range of **RuB** valves and consult with your supplier for special applications.*

*Your local source is:*

