

Woltman meters



## Woltman meters

The comprehensive range for every application

ZENNER® offers a comprehensive range of large water meters, from the various standard models to meters for special purposes.

All the following series WP, WPH, WS, WPH-MF and WS-MF Woltman meters are **completely dry dial meters**. Only the turbine works in the wet chamber. The roller counter runs in the dry. It is encapsulated, evacuated, safe against flooding and can be rotated to any position. There is no possibility of the transparent cover becoming coated. The read-out is therefore not inhibited in any way.

The **head loss** caused by measurement is **very slight**.

Our Woltman meters are characterised by **high long-term stability**.

These ZENNER® products are based on almost 100 years' experience. Over the course of time we succeeded in developing increasingly better and **resistant products**. The materials for the bearings undergo continuing long-term tests under the most extreme conditions.

- WP the inexpensive standard model
- WP-N prepared for retrofitting with reed contact device or infrared pulsing device
- WPI-N fitted with contact or pulsing device.



- the value-for-money standard meter
- can be used for measuring flow rates with little fluctuation, e.g. as flow-rate meters in front of and behind pumps, and in source supply lines
- Measuring insert not removable: The complete meter is replaced
- Regulation on the side in the body
- for cold water up to 30°C (safe up to 50°C)
- for hot water up to 120°C (safe up to 150°C)
- Operating pressure: PN 16
- Flange bore-hole conforms to PN 10 (alternative PN 16)
- EC type approval in classes A and B

## Technical data

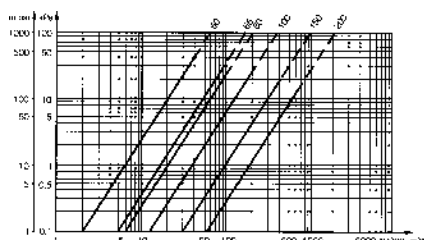
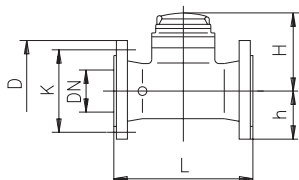

Nominal flow	Qn	m³/h	15	25	40	60	150	250
Maximum flow	Qmax	m³/h	30	50	80	120	300	500
Max. flow short-term	-	m³/h	40	70	110	180	350	650
Permissible constant load	Qn	m³/h	20	35	55	90	175	325
Transitional flow	Qt	m³/h	3	4	8	12	20	50
Minimum flow	Qmin	m³/h	1.2	1.2	1.2	1.8	3.5	7
Start-up flow	-	m³/h	0.5	0.5	0.5	0.8	1.4	3.0
Flow rate with 0.1 bar head loss	-	m³/h	20	55	65	120	300	600
Nominal diameter	DN	mm	50	50/65	80	100	150	200
Register range	-	m³	999.999				9.999.999	
	-	l	1		10		100	
Overall length	L	mm	200		225	250	300	350
		mm	200			250	300	350
Height	H	mm	108	125		135	165	190
	h	mm	72	83	95	105	135	160
Flange connection according to DIN 2501	D	mm	165	185	200	220	285	340
	K	mm	125	145	160	180	240	295
Number of screws	-	pcs.	4		8(4)	8		8(12)
Weight	-	kg	8.2	10	11.6	14.8	24.8	40.3

For transitional flow Qt and minimum flow rate Qmin see table on last page of product group Multi-jet meters



- The robust device for extreme applications
- Used for flow rates with little fluctuation, e.g. as a flow-rate meter in front of and behind pumps in source supply lines
- Measuring insert replaceable without removing the body
- Regulation at measuring insert (unlike WP version in the body)
- Body made of high-quality grey cast iron
- Brass sealing plate
- EC type approval in classes A and B
- For cold water up to 30°C (safe up to 80°C)
- For hot water up to 120°C (safe up to 150°C)
- Operating pressure: PN 16
- Flange bore hole conforms to PN 10 (alternative PN 16)
- For horizontal and vertical installation
- High-quality epoxy coating
- DN 50 and DN 65 with improved measurements: better than class B

- For recording flow rates in any direction of flow with high dynamics
- Horizontal installation (vertical also possible)
- Measuring insert replaceable without removing body
- Regulation in the measuring insert (not in the body)
- EC type approval in classes A and B
- For cold water up to 30°C (safe up to 50°C)
- For hot water up to 120°C (safe up to 130°C)
- Operating pressure: PN 16 and PN 25
- Flange bore hole conforms to PN 10
- Wide measuring range for all nominal widths
- Pulsing device suitable for ABB and hydrometer Woltman meters

## Woltmanzähler

### WPH

technically advanced WP,  
measuring insert removable

### WPH-N

pulse-capable for pulse outputs

### WPHI-N

fitted with reed contact device

### WPH-MF-N

can be retrofitted either with reed, infrared or Namur device

### WPH-MF

is fitted with one of the above devices

Nominal flow	Qn	m <sup>3</sup> /h	15	25	40	60	150	250	400	
Maximum flow	Qmax	m <sup>3</sup> /h	30	50	80	120	300	500	800	
Max. flow short-term	-	m <sup>3</sup> /h	70	100	150	250	350	650	1200	
Permissible constant load	Qn	m <sup>3</sup> /h	35	50	90	125	250	325	600	
Transitional flow	Qt	m <sup>3</sup> /h	2	5	6	6	12	12	20	
Minimum flow	Qmin	m <sup>3</sup> /h	0.7	0.75	0.8	1.5	3.5	6.5	12	
Start-up flow	-	m <sup>3</sup> /h	0.25	0.3	0.3	0.5	1.5	2.5	5	
Flow rate with 0.1 bar head loss	-	m <sup>3</sup> /h	38	60	65	100	310	550	800	
Nominal diameter	DN	mm	50	65	80	100	150	200	250	
Register range	-	m <sup>3</sup>	999.999				9.999.999			
	-	l	1				10			
Overall length	L	mm	200		225	250	300	350	450	
		mm	200		250	300	350	450		
Height WPH	H	mm	148	147	145	150	210	210	222	
	h	mm	72	83	95	105	135	160	193	
Height WPH-MF	H	mm	123		140		212		236	
	h	mm	75	83	94	106	135	163	203	
Flange connection according to DIN 2501	D	mm	165	185	200	220	285	340	405	
	K	mm	125	145	160	180	240	295	350	
Number of screws	-	pcs.	4		8(4)	8	12	8(12)	12	
Weight WPH	-	kg	12.6	13.2	14.2	17.7	38	48.8	75	
Weight WPH-MF	-	kg	10.2	11.2	14.1	19.4	32.5	45	108	

For transitional flow Qt and minimum flow rate Qmin see table on last page of product group Multi-jet meters. WPH 125, 300, 400 and 500 are available on request

## Technical data

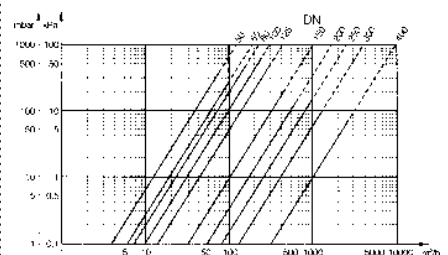
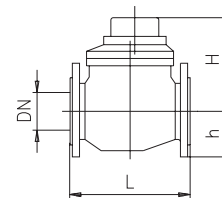

## Woltman meters

### WS

robust, for extreme applications

### WS-N

prepared for retrofitting with reed contact device  
or infrared pulsing device

### WSI-N

fitted with reed or infrared measurement output



- Suitable for fluctuating flow rates; typical uses are, for example, in schools, holiday complexes and industrial plants
- For horizontal installation
- Measuring insert replaceable without removal of body
- Regulation in measuring insert (not in body)
- For cold water up to 30°C (safe up to 80°C)
- For hot water up to 120°C (safe up to 150°C)
- Operating pressure: PN 16
- Flange bore-hole conforms to PN 10 (alternatively PN 16)
- Measurements better than class B

### WS-MF-N

prepared for retrofitting with either reed, infrared or Namur device

### WS-MF

fitted with one of the above pulse outputs



- For counting and measuring fluctuating flow rates
- For horizontal installation
- Measuring insert replaceable without removal of body
- Regulation in measuring insert (not in body)
- EC type approval in class B
- Substantially extended measuring range towards small flow rates than documented in metrology class
- For cold water up to 30°C (safe up to 50°C)
- For hot water up to 120°C (safe up to 130°C)
- Operating pressure: PN 16
- Flange bore-hole conforms to PN 10
- Pulsing device suitable for ABB and hydrometer Woltman meters

## Technical data

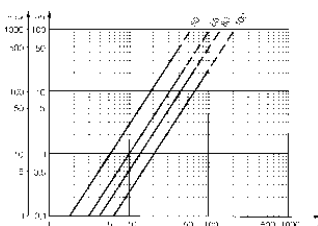
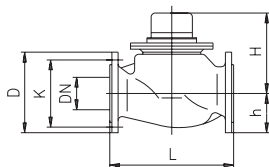

Nominal flow	Qn	m³/h	15	25	40	60	150 (MF)
Maximum flow	Qmax	m³/h	30	50	80	120	300
Max. flow short-term	-	m³/h	30	70	110	180	350
Permissible constant load	Qn	m³/h	20	40	55	90	200
Transitional flow	Qt	m³/h	1	3	3	5	10
Maximum flow	Qmin	m³/h	0.15	0.2	0.2	0.3	0.8
Start-up flow	-	m³/h	0.05	0.07	0.07	0.1	0.4
Flow rate with 0.1 bar head loss	-	m³/h	18	35	40	60	160
Nominal diameter	DN	mm	50	65	80	100	150
Register range	-	m³	999.999				9.999.999
	-	l	1				10
Overall length WS	L	mm	270	300		360	-
	L	mm	300	300	350	350	-
Height WS	H	mm	117	145	150	220	-
	h	mm	73	87	95	105	-
Overall length WS-MF	L	mm	270	300		360	500
		mm	300		350		500
Height WS-MF	H	mm	135	202	202	207	351
	h	mm	85	97	102	113	141
Flange connection according to DIN 2501	D	mm	165	185	200	220	285
	K	mm	125	145	160	180	240
Number of screws	-	pcs.	4		8(4)		8
Weight WS	-	kg	12.7	19	21	33	-
Weight WS-MF	-	kg	14.5	24.5	25.5	31.5	79.5

For transitional flow Qt and minimum flow rate Qmin see table on last page of product group Multi-jet meters.

## Woltman meters

### FLYPPER

The electronic counter module

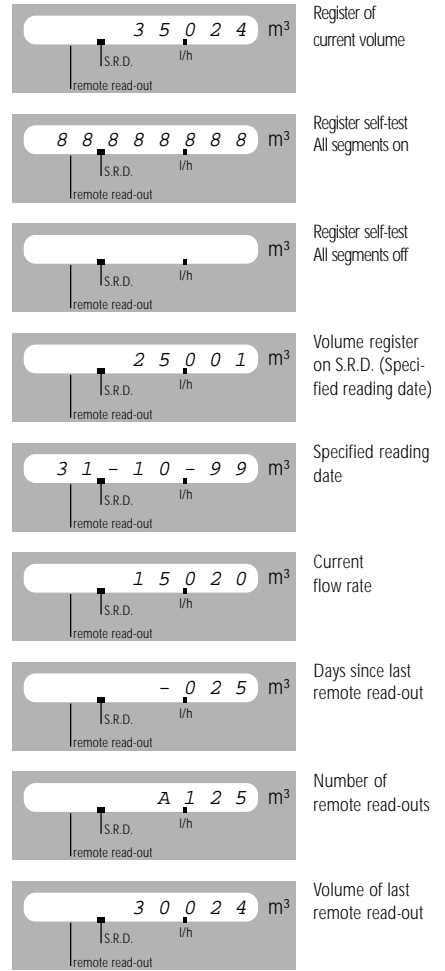

**Previously** it was very time-consuming and **costly** to read meters and document the results. Extensive lists of addresses had to be "combed through" and meters had to be read in flooded manholes or other locations which are difficult to access. Under such aggravating conditions, incorrect readings cannot be ruled out either, and incorrect entries can also result when data is being processed.

**Today** such sources of error can be avoided and the data reading can be realized **quickly and economically**. With the FLYPPER module it is no longer necessary to access man holes. A special seal in the devices guarantees flooding safety to protection type IP 68. The data can then, for example, be recorded and stored via the M-Bus socket at the top of the manhole **directly in the laptop**.



Can also be combined with **multidata S1** and **pulse counter module** in M-Bus networks from ZENNER

It is also possible to use the **PSION workabout®** as a read-out system.

## Woltman meters

### Combination meters



WPV-MF-N



WPV-N

#### New: very large measuring range:

DN 50	15	-	30.000 l/h
DN 80	16	-	80.000 l/h
DN 100	15	-	120.000 l/h
DN 150	30	-	300.000 l/h

Combination meters are designed to record water volumes **with very high or very low flow rates**. In the event of fire, for example, at a tap position where normally only very small quantities of water are drawn per unit time, a high flow rate is required. In this event, the switching valve opens and the volume which has flowed through is recorded by the larger meter.

Our combination meters are characterised by **high accuracy of measurement** even in the switch-over range, as well as by minimum head loss at maximum load. They are simple in design, durable in operation and are relatively light in weight.

One further benefit is their overall length which is identical with the standard WS meters, which are also used here. This series thus offers every advantage of the WS series.

Both types can be extended with the adjustable adapter piece. It is available in sizes DN 50-150.

The main meter is a dry dial meter in each case, while the small auxiliary meter is a wet dial meter. Looking in the direction of flow, the auxiliary meter is fitted to the right of the main meter or alternatively in special designs to the left. The auxiliary meter is better than class C.

The combination meters are intended for use with cold water up to 30°C.

The fitting position is horizontal. The maximum operating pressure is 16 bar. The flanges are bored to DIN 2501; PN 10.

All meters have **EC type approval** and are certified to EO6.

Model IP 68 is designed for installation in the manhole. The counter is safe against flooding.



NEW: TURBO VERBUND  
see Special Brochure



adjustable adapter piece

## Woltman meters

### Technical data WPV

Main meter	Nominal flow	Qn	m <sup>3</sup> /h	15	40	60	150	
	Maximum flow	Qmax	m <sup>3</sup> /h	30	80	120	300	
	Register range	-	m <sup>3</sup>	999.999				9.999.999
l			1				10	
Secondary meter	Nominal flow	Qn	m <sup>3</sup> /h	2.5		10		
	Register range	-	m <sup>3</sup>	99.999				
			l	0.05				
Nominal diameter	DN	mm	50	80	100	150		
Overall length	L	mm	270 (300)	300 (350)	360 (350)	500 ±15		
Width	B	mm	185	200	215	295		
	b	mm	95	110	125	150		
Height	H	mm	220	240	255	354		
	h	mm	75	95	105	135		
Flange connection	K	mm	125	160	180	240		
Screw hole diameter	l	mm	18				22	
Number of screws	-	pcs.	4	8(4)	8			
Switch-over flow	-	m <sup>3</sup> /h	1.6		2.5	6.2		
			1.1		1.9	4.8		
Weight	-	kg	19	24	30	75		

For transitional flow Q<sub>t</sub> and minimum flow rate Q<sub>min</sub> see table on last page of product group Multi-jet meters.

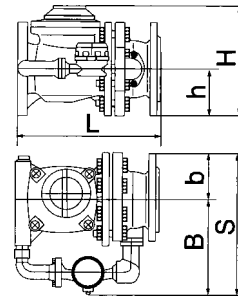

### Technical data WPV-MF

Main meter	Nominal flow	Qn	m <sup>3</sup> /h	15	40	60	150	
	Maximum flow	Qmax	m <sup>3</sup> /h	30	80	120	300	
	Register range	-	m <sup>3</sup>	999.999				9.999.999
l			1				10	
Secondary meter	Nominal flow	Qn	m <sup>3</sup> /h	2.5		10		
	Register range	-	m <sup>3</sup>	99.999				
			l	0.05				
Nominal diameter	DN	mm	50	80	100	150		
Overall length	L	mm	270	300	350 / 360	500 ±15		
Width	B	mm	190	220			290	
	b	mm	85	110	110	145		
Height	H	mm	198	234	246	347		
	h	mm	75	94	106	135		
Flange connection	K	mm	125	160	180	240		
Screw hole diameter	l	mm	18				22	
Number of screws	-	pcs.	4	8(4)	8			
Switch-over flow	-	m <sup>3</sup> /h	1.9		2.8	6.2		
			1.2		1.6	4.8		
Weight	-	kg	17.4	25.4	32/33	68		

For transitional flow Q<sub>t</sub> and minimum flow rate Q<sub>min</sub> see table on last page of product group Multi-jet meters.

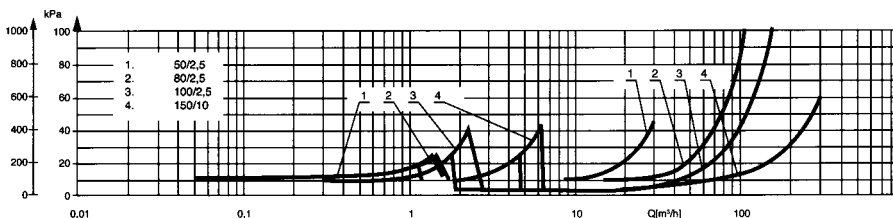
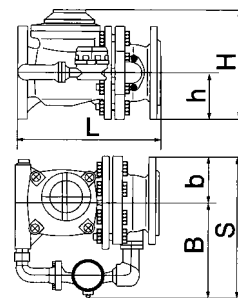

### Head loss curves

## Woltman meters

WI

Irrigation meter for sprinkling  
fresh and dirty water  
Well meter



Heavily soiled water, e.g. in agriculture, sewage treatment plants or waste-water processing plants, requires **particularly robust meters**.

The measuring insert is fitted in the top area of the pipe, where there are mostly only a few suspended particles in the water which flows through. The Woltman irrigation meter can thus even function in water containing **up to 30% pollution**.

The irrigation meter is, however, also frequently used for fresh water as a control meter where flow rates fluctuate little. It is the ideal low-speed well meter. Irrespective of the power supply, it is the **cost-effective alternative to induction flow meters**.

The WI is a dry dial meter with magnetic coupling. It can also be installed in pipes which run **vertically or horizontally**.

However, a filter is recommended for soiled water.

The roller counter is encapsulated and can be secured with a padlock. The removable measuring insert is the same for all sizes.

Model WI-I has the same design as model WI, but is fitted with a reed switch.

### Measuring accuracy

$Q_{max}-Q_t$ :  $\pm 3\%$  (class A+B values)

$Q_t-Q_{min}$ :  $\pm 5\%$  (class A values)

**Flange bore hole** to DIN 2532,  
DIN 2501 PN10

### Pulse values:

0.1, 1, 10 m<sup>3</sup>/Impuls

### Operating pressure:

1.6 MPa

16 bar

## Technical data

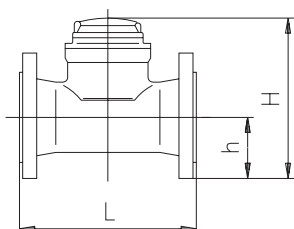

Nominal flow	Q <sub>n</sub>	m <sup>3</sup> /h	30	50	90	125	175	250	450
Max. load	Q <sub>max</sub>	m <sup>3</sup> /h	70	120		300		500	800
	short-term Q <sub>max</sub>	m <sup>3</sup> /h	100	120	150	300	350	500	900
Transitional flow	Class A Q <sub>t</sub>	m <sup>3</sup> /h	9	18		45		75	120
	Class B Q <sub>t</sub>	m <sup>3</sup> /h	6	12		30		50	80
Minimum flow	Class A Q <sub>min</sub>	m <sup>3</sup> /h	2.4	4.8		12		20	32
Nominal diameter	DN	mm	50	65	80	100	125	150	200
Register range	-	m <sup>3</sup>	10 <sup>7</sup>						
	-	m <sup>3</sup>	0.005						
Overall length	L	mm	200	200	225	250	250	300	350
Height	h	mm	75	85	95	105	120	135	180
	H	mm	230	240	250	260	275	305	335
Weight	-	kg	11	12	14	18	22	27	40



Contact load: 24 V, 0.2 A  
 Cable: 2 x 0.25 mm<sup>2</sup>  
 Cable length: 2 m

The reed switch (low frequency switch) supplies a low-resolution pulse frequency in proportion to the flow rate in combination with the counter of the water meter and the magnets, which are installed as standard. The reed switch is used for the **remote counting** and registration of through-flowing volumes of water by means of the summarizing electronic pulse output counter, printer or memory. It can be connected to the IZM 972 pulse counter module and can thus be integrated into **M-Bus networks**. Type KG-ZR is suitable for series WPHI-N and WSI-N Woltman meters. Series KG-R functions in exactly the same way as KG-ZR, but has been specially developed for the Woltman-MF series



KG-ZR für Bauart N



KG-R für Bauart MF

## Low-resolution contact device

### Reed switch

KG-ZR  
 KG-R



Together with the initiator, which is fitted as standard in the counter, the pulsing device (low-frequency switch) a high-resolution pulse

frequency proportionate to the flow rate. An infrared light beam serves as the pulsing device, and a reflecting strip embossed onto the wheel disc serves as the initiator. The pulsing device can be connected to a **measuring signal converter** which supplies analog flow rate values, e.g. for monitoring breaks in the pipework, for controlling pumps and slide valves or for dosing quantities. Version IG-ZR is suitable for series WPHI-N and WSI-N Woltman meters. Series IG-IR has the identical function as IG-ZR, but has been specially developed for the Woltman-MF series. The Namur receiver (IG-IN) is available for all version WPH-MF and WS-MF Woltman meters.

## High-resolution pulsing device

### IR light beam / Namur device

IG-ZR  
 IG-IR  
 IG-IN



IG-ZR for type N



IG-IR for type MF



IG-IN for type MF

Triple-conductor version:  
 3 x 0.25 mm<sup>2</sup>  
 Cable length: 2 m

	KG-ZR	KG-R	IG-ZR	IG-IR	IG-IN
WPH	-	-	-	-	-
WP	-	-	-	-	-
WS	-	-	-	-	-
WPH-N	○		○		
WP-N					
WS-N					
WPH-MF-N		○		○	○
WS-MF-N					
WPHI-N	●		●		
WPI-N					
WSI-N					
WPH-MF		●		●	●
WS-MF					

- not retrofittable ○ retrofittable ● retrofitted

Pulse rate	10	100	1000	10000
DN 50	◇	✓	✓	
DN 65	◇	✓	✓	
DN 80	◇	✓	✓	
DN 100		✓	✓	
DN 125		✓	✓	
DN 150	◇	✓	✓	✓
DN 200		◇	✓	✓
DN 250		◇	✓	✓
DN 300			✓	✓
DN 400			✓	✓

✓ possible version ◇ special version for KG-R

## Retrofit options and pulse values

WPH-N, WPHI-N, WPH-MF-N, WSI-N and WS-MF-N for KG-ZR / KG-R contact devices

WS up to DN 100 only  
 WP up to DN 200 only

## Installation

### Contact and pulsing devices

#### Type WPI-N / WSI-N

Remove the customer seal, unscrew the four screws in the protective covering and take off the protective cap. Slide the contact device into the shaft provided in the protective cap, feed the cable outwards through the opening and reassemble in reverse order.

#### Type WPHI-N

Remove the customer seal, unscrew the two screws in the covering and take off the protective cap. Slide the contact device into the shaft provided in the mounting ring, feed the cable outwards through the opening and reassemble in reverse order.

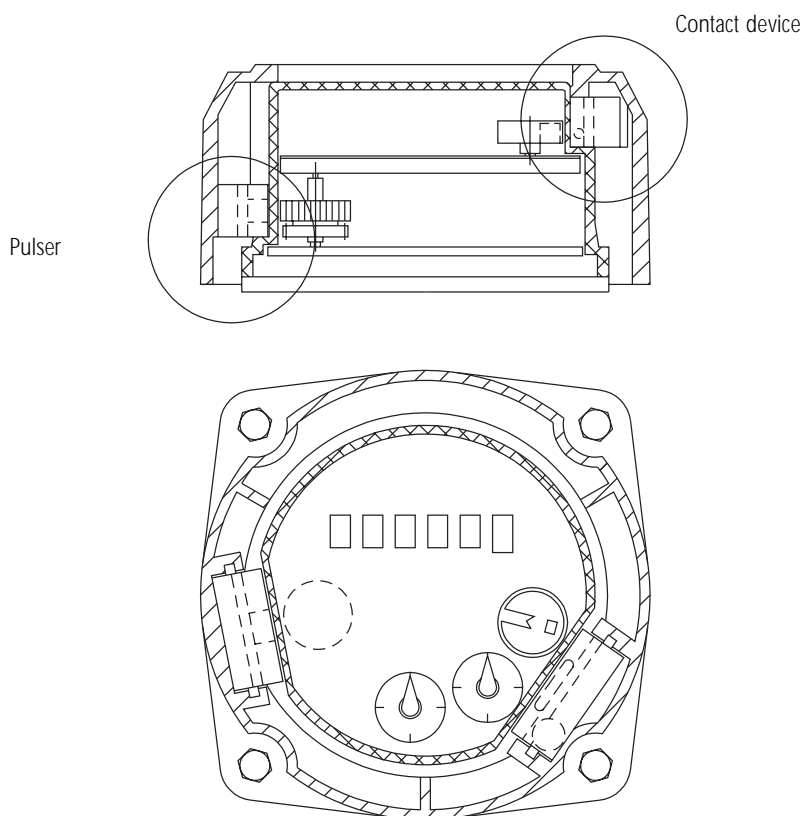

### Combined honeycomb rectifier

**Perfect measuring results** in Woltman meters require that the water strikes the meter at a steady flow.

In order to prevent **excessive turbulence** in flow, **stabilizing sections** in front of the meters **are prescribed**. This task is also carried out by the flow straighteners which are fitted in front of and behind the meter.

Should, however, an irregular rate of flow occur in the pipe cross section, other or additional measures must be taken so that the result of the measurement is not falsified. This problem occurs if a meter is installed immediately after a valve bend in the pipe or if several pumps feed one collecting pipe.

#### **A honeycomb rectifier solves this problem.**

32 square axial-flow channels destroy the angular momentum of the water inside the pipeline. Located at the inlet of the honeycomb section is a perforated disc whose cross section is approximately half the size of the cross section of the pipe. The inflowing water is damped and the square channels which follow destroy any angular momentum.

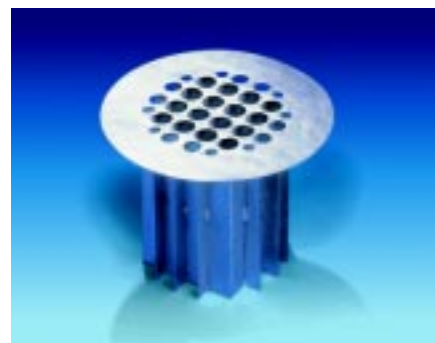

The head loss caused by the honeycomb rectifier at a flow rate of 3 m/sec is approximately 0.1 bar. The metal flange on the perforated disc is used to secure the rectifier between two flanges with the honeycomb section pointing in the direction of flow. A length of blank pipe at least 5 pipe diameters should be fitted in front of the meter. If the rectifier is positioned at a short distance in front of the meter then minus-range deviations in measurements can occur.

The honeycomb rectifier is made of stainless steel.

DN 50 - 500 mm  
 Ø holding flange - Ø sealing strip

## Meters ordering data

Model	Nominal flow rate m <sup>3</sup> /h	DN	Overall length	Pulse rate	Type	Order no.
WPH-N * PN 10/16, 30°C	15	50	200 mm	selectable	WPHI-K-050	12B 001
	25	65	200 mm	selectable	WPHI-K-65	12B 002
	40	80	225 mm	selectable	WPHI-K-80	12B 003
	60	100	250 mm	selectable	WPHI-K-100	12B 004
	150	150	300 mm	selectable	WPHI-K-150	12B 005
	250	200	350 mm	selectable	WPHI-K-200	12B 006
	400	250	450 mm	selectable	WPHI-K-250	12B 007
WPHI-N PN 10/16, 30°C	15	50	200 mm	1000	WPHI-IK-050	12B 008
WPH PN 10/16, 30°C	15	50	200 mm		WPH-K-050	12B 009
WPH-MF-N * PN 25/40, 30°C	15	50	200 mm	selectable	WPH-MF-050	12B 010
WPH-MF-N * PN 10/16, 90°C	15	50	200 mm	selectable	WPH-MF-050	12B 011
WS-N * PN 10/16, 30°C	15	50	270 mm	selectable	WSI-K-050	11B 001
	25	65	300 mm	selectable	WSI-K-065	11B 002
	40	80	300 mm	selectable	WSI-K-080	11B 003
	60	100	360 mm	selectable	WSI-K-100	11B 004
	150	150	500 mm	selectable	WSI-K-150	11B 005
WSI-N PN 10/16, 30°C	15	50	270 mm	1000	WSI-IK-050	11B 006
WS	15	50	270 mm		WS-K-050	11B 009
WS-MF-N * PN 25/40, 30°C	15	50	270 mm		WS-MF-050	11B 007
WS-MF-N * PN 10/16, 90/120°C	15	50	270 mm		WS-MF-050	11B 008
WP	15	50	200 mm		WP-K-050	10B 001
WP-N	15	50	200 mm	selectable	WPI-K-050	10B 002
WPI-N	15	50	200 mm	1000	WPI-IK-050	10B 003
WI PN 10/16, 50°C		65	200 mm		WI-K-065	14B 001
		80	225 mm		WI-K-080	14B 002
		100	250 mm		WI-K-100	14B 003
		125	250 mm		WI-K-125	14B 004
		150	300 mm		WI-K-150	14B 005
		200	350 mm		WI-K-200	14B 006
WI-I	50	65	200 mm	1000	WI-IK-065	14B 007
WPV-N PN 10/16, 30°C	15 **	50	270 mm		WPV-N-050	15B 001
	40 **	80	300 mm		WPV-N-080	15B 002
	60 **	100	350/360 mm		WPV-N-100	15B 003
	150 **	150	500 ± 15 mm		WPV-N-150	15B 004
	250	200	1200 mm		WPV-N-200	15B 005
WPV-MF-N PN 10/16, 30°C	15	50	270 mm		WPV-MF-N-050	15B 006
	40	80	300 mm		WPV-MF-N-080	15B 007
	60	100	350/360 mm		WPV-MF-N-100	15B 008
	150	150	500 ± 15 mm		WPV-MF-N-150	15B 009

### WPH-N

Standard version  
available up to DN 500

### Pulse version

complete with contact device KG-ZR (example)

Pulsing device cannot be retrofitted

### WS-N

Standard version

### Pulse version up to DN 150

complete with contact device KG-ZR (example)

Pulsing device cannot be retrofitted

Pulsing device can be retrofitted, but  
PN 25/40, available up to DN 150

Pulsing device can be retrofitted, but  
90°C, available up to DN 150

### WP, WP-N, WPI-N

available up to DN 250

### WI

Pulsing device cannot be retrofitted

complete with pulsing device,  
available up to DN 200

### WPV

without adapter piece

with adapter piece

### WPV-MF

without adapter piece

\* pulsing device can be retrofitted; please state pulse sequence and type of device beforehand; we will be pleased to advise you

\*\* in factory-tested version

all MF series also available with FLYPPER counter; other lengths and pulse sequences also available to suit all sizes

## Accessories ordering data



Model N



Model MF



Model N



Model MF



Model MF

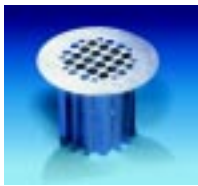

Model	Qty. in package	DN	Overall length	Type	Order no.
Adjustable spacer	1	50	327 ±20 mm	BWA-050	65B 001
		80	397 ±40 mm	BWA-080	65B 002
		100	442 ±25 mm	BWA-100	65B 003
		150	500 mm	BWA-150	65B 004
Reed contact device for model N	1			KG-ZR	65B 005
Reed contact device for model MF				KG-R	65B 006
Infred pulser for model N	1			IG-ZR	65B 007
Infred pulser for model MF				IG-IR	65B 008
Inductive Namur device for model MF	1			IG-IN	65B 009
Combined honeycomb rectifier	1	50		WGR-050	65B 010
		65		WGR-065	65B 011
		80		WGR-080	65B 012
		100		WGR-100	65B 013
		125		WGR-125	65B 014
		150		WGR-150	65B 015
Filter for Woltman meter	1	50	200	FWZ-050	65B 019
		80	225	FWZ-080	65B 020
		100	250	FWZ-100	65B 021