

Note per l'installazione e manutenzione

- Per temperature sotto 0°C proteggere il prodotto dal gelo;
 - Prima di mettere in funzione il prodotto é necessario spurgare le tubazioni;
 - Utilizzare solo acqua proveniente dalla rete idrica, in particolare non utilizzare acqua salata e/o acqua contenente sabbia;
 - Non alterare o modificare le caratteristiche del prodotto.
 - Per la pulizia del prodotto non utilizzare assolutamente prodotti contenente solventi, abrasivi, agenti corrosivi acidi o alcalini, spugne abrasive e tamponi con fili metallici, poiché potrebbero alterare irreversibilmente le superfici trattate;
- L' AZIENDA declina ogni responsabilità per utilizzi al di fuori di quanto specificato nelle note per l'installazione.

Installation notes and maintenance

- when temperature is below 0° C protect the product from frost
 - to drain main pipes before operating the waste
 - to use main water only ; it is important to avoid salt water and/or water with sand
 - do not use cleaning products containing solvents , acid or alkaline corrosive substances and do not use abrasive sponge or any metallic item to clean the waste as they could irreversibly alter the treated surface
- The MANUFACTURER disclaims any responsibility for use which fails to comply with the installation notes.

Installatievoorschrift en handleiding

- Bij temperaturen onder 0°C het product beschermen tegen vorst.
- Spoel de leidingen voorafgaand aan installatie door.
- Alleen te gebruiken voor drinkwater, niet geschikt voor zand- of zouthoudend water.
- Pas, of verander het product op geen enkele wijze aan.
- Gebruik geen schoonmaakproducten die oplosmiddelen, zuren of alkalische corrosieve substanties (zoals zoutzuur, mierenzuur, azijnzuur, fosforzuur) bevatten of schuursponsjes al dan niet met metaaldraad. Deze kunnen het product en/of oppervlakte onherstelbaar aantasten.
- De fabrikant wijst elke verantwoordelijkheid af bij gebruik welke afwijkt van deze montagehandleiding.

Notas para la instalacion y manutencion

- Para temperaturas bajo 0°C , proteger el producto del hielo;
 - Antes de poner en función el producto es necesario purgar las tuberías;
 - Utilizar solo agua proveniente de la red hidráulica, particularmente no utilizar agua salada y/o agua que contenga arena; No cambiar o modificar las características del producto;
 - No utilizar para la limpieza del producto productos que contengan disolventes, agentes corrosivos, ácidos o alcalinos, espumas abrasivas o tampones con hilos metálicos, en caso contrario, se pueden dañar irreversiblemente las superficies tratadas.
- La Empresa Constructora no se responsabiliza de cualquier uso distinto a lo indicado en las NOTAS PARA LA INSTALACION.

Installationsanweisungen und Wartung

- Bei Temperaturen unter 0°C muss das Produkt vor Frost geschützt werden;
- Vor der Montage des Produktes sind die Rohrleitungen gut durchzuspülen;
- Verwenden Sie nur Leitungswasser, insbesondere verwenden Sie kein Salzwasser und/ oder sandhaltiges Wasser;
- Die Einzelteile des Produktes dürfen nicht verändert werden;
- Zur Reinigung des Produktes verwenden Sie keine Reinigungsmittel, die Lösungsmittel, Schleifmittel, scheuernde oder ätzenden Mittel enthalten, sowie Waschlapen mit synthetischen oder metallischen Fasern, die die behandelten Oberflächen irreversibel beschädigen könnten.
- Unsere Firma übernimmt keinerlei Haftung bei von dem im Installationsblatt gegebenen Anweisungen abweichendem Gebrauch.

"Leggenda 166/2009 - Per quanto previsto dalla legge si dichiara che alcuni componenti di questo prodotto sono di importazione extra UE. Testati, assemblati e collaudati all'interno del nostro stabilimento"
"Bylaw n. 166/2009 - As bylaw enacted we state that some components of this product are imported from extra-Eu countries. Tested, assembled and inspected inside our factory."

08/2020 CRHATT17743A02

ISTRUZIONI DI MONTAGGIO

INSTALLATION INSTRUCTIONS

NOTICE DE MONTAGE

MONTAGEANLEITUNG

INSTRUCCIONES DE MONTAJE

MONTAGEHANDLEIDING

SCARICHI PER DOCCIA DOUCHEBAKAFVOERPLUG

AD450 - AD455 - AD470

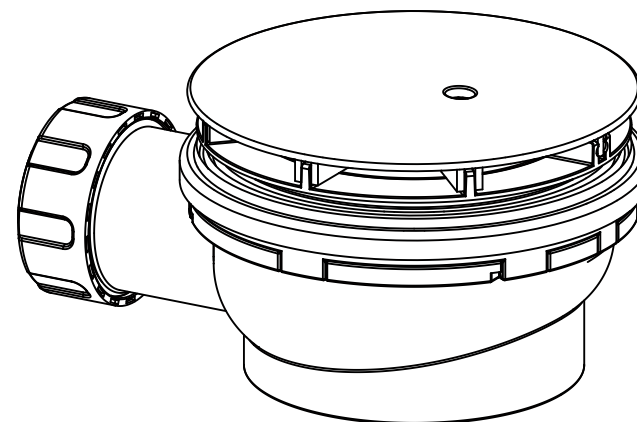

AD450

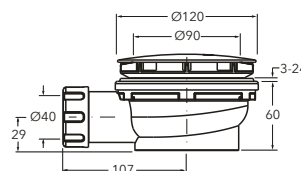

AD455

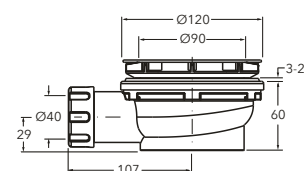

AD470

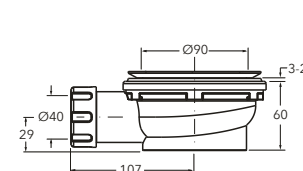

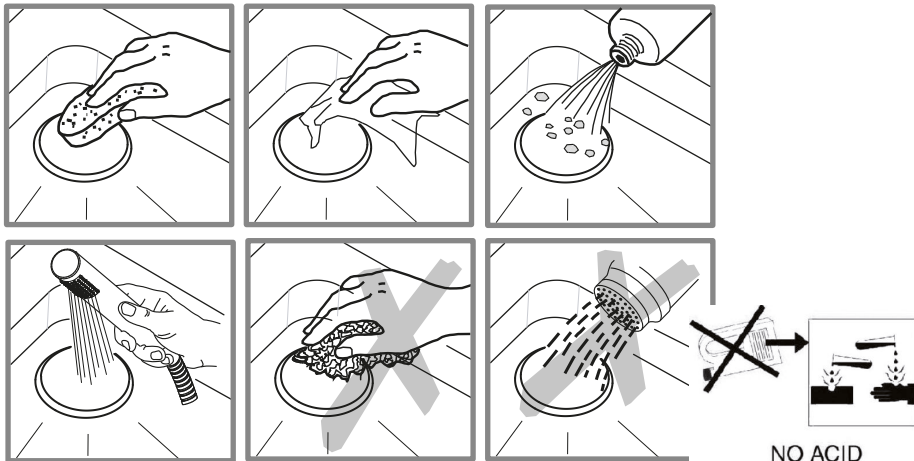

Montaggio e Pezzi di Ricambio - Installation And Spare Parts - Montage et pièces détachées
 Montage und Ersatzteile - Montaje y piezas de recambio/Installatie en reserveonderdelen

Manutenzione / maintenance / entretien
 Wartung / mantenimiento / onderhoud

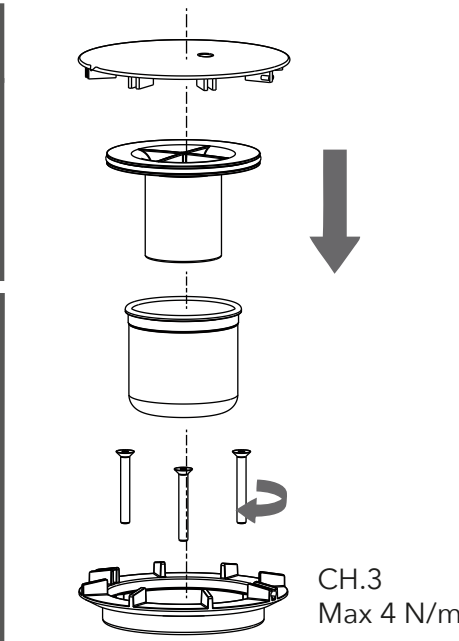
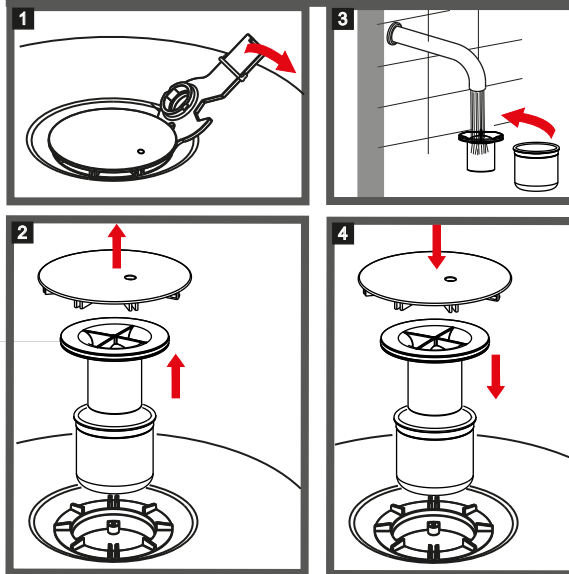

CH.3
 Max 4 N/m

H.
 5-25

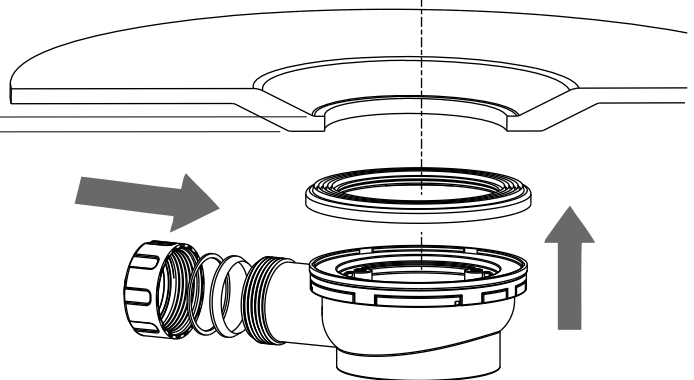

per - for - für - para - voor
 AD470

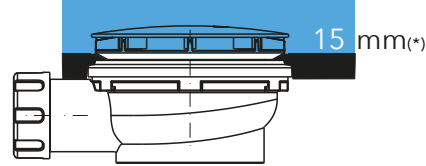
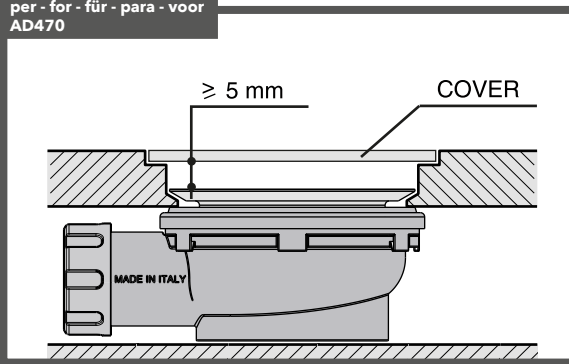

AD455



AD450

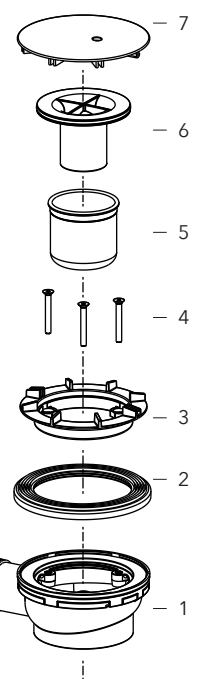

AD470

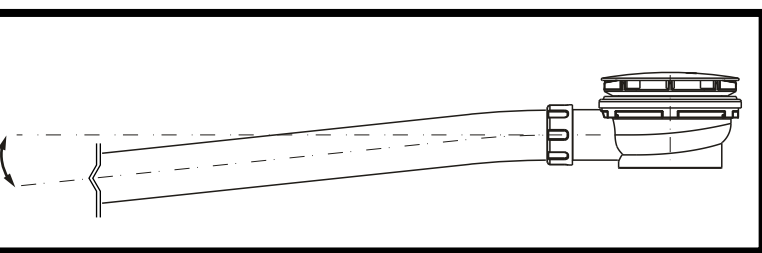
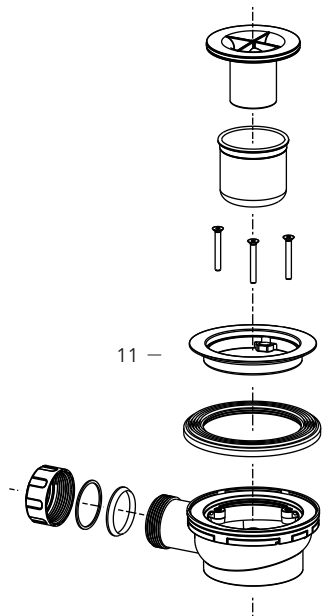

portata (l/s) - flow rate (l/s) Abflaufleistung (l/s) Línea de drenaje (l/s) doorstroomhoeveelheid [l/sec]	AD450	EN 274
(*) livello acqua - water level Anstauhöhe - nivel del agua Wasserstand	0,41	≥ 0,4